

LOX Tanks

Installation, Operation and Maintenance Manual

Published by Pneumatech Medical Gas Solutions

All possible care has been taken in the preparation of this publication, but Pneumatech Medical Gas Solutions accepts no liability for any inaccuracies that may be found.

Pneumatech Medical Gas Solutions reserves the right to make changes without notice both to this publication and to the product which it describes.

Copyright © 2015 Atlas Copco All rights reserved.

No part of this publication may be reproduced, transmitted, transcribed, or stored in a retrieval system or translated into any human or computer language in any form or by any means without the prior permission of Pneumatech Medical Gas Solutions.



Important

Personnel must make themselves familiar with the contents of this manual and the function of the unit before installing, operating or maintaining any LOX Tanks

Information contained in this manual is correct at the date of publication. The policy of Pneumatech Medical Gas Solutions is one of continuous product improvement. Pneumatech Medical Gas Solutions reserves the right to make changes that may affect instructions in this manual without prior notice.

For any enquiry regarding the servicing or repair of this device, contact the nearest accredited Pneumatech Medical Gas Solutions agent, or communicate directly with:



Pneumatech Medical Gas Solutions
Unit 18 Nuffield Centrum
Nuffield Way
Abingdon
Oxfordshire
OX14 1RL
UK

<http://www.p-mgs.com>

Sales

Tel: 44 (0) 1235 463010
Fax: 44 (0) 1235 463011
sales@p-mgs.com

Spares

Tel: 44 (0) 1235 463053
Fax: 44 (0) 1235 463011
spares@p-mgs.com

Service

Tel: 44 (0) 1235 463051
Fax: 44 (0) 1235 463011
service@p-mgs.com

Any complaints about the products or services provided by Pneumatech Medical Gas Solutions, please give as much of the following information as possible:

Product Part Number
Lot/ Batch Number
Approximate date of purchase
Apparent fault.

Complaints

T: 44 (0) 1235 463010
F: 44 (0) 1235 463011
complaints@p-mgs.com

Issue Record

Issue No.	Reason for Change	Pages affected	Date
00	First Issue	All	2015

Introduction

This manual contains information needed to install, operate and maintain the Pneumatech Medical Gas Solutions (Pneumatech MGS) LOX Tanks

The contents of this manual are intended to be read and used by suitably qualified personnel.

WARNINGS, CAUTIONS and NOTES

The following Warnings, Cautions, and Notes must be read and understood before using the LOX Tanks.

Warnings!

Warnings tell you about dangerous conditions that could lead to death or serious injury to the user that can occur if you do not obey all of the instructions in this manual.

WARNING! Read through this entire instruction manual before using or showing others how to use this equipment. Attempting to use this device without a thorough understanding of its operation may result in patient or user injury or death.

WARNING! Do not attempt to modify this device. Failure to observe this may result patient or user injury or death.

WARNING! LOX Tanks must be protected from access by unauthorised personnel.

WARNING! Risk of fire or explosion: Do not lubricate this product with oil or grease. Safe and compatible lubricants can be obtained from Pneumatech Medical Gas Solutions if necessary.

WARNING! Do not use this product if it is damaged in any way, or if there is evidence of contamination internally or on any of gas wetted connections (e.g. debris, particles, oil, lubricant or grease).

Cautions!

Cautions tell you about dangerous conditions that can occur and cause damage to the equipment if you do not obey all of the instructions in this manual.

Select or add Cautions as appropriate as appropriate

CAUTION! Use of sub-standard or inappropriate parts and materials may damage the Manifold System and invalidate the warranty. Only use genuine Pneumatech Medical Gas Solutions spare parts.

CAUTION! Always open valves slowly.

CAUTION! Be careful not to over-torque face seal fittings.

CAUTION! Only use leak detection fluids that are compatible with the materials being tested.

CAUTION! Always wash leak detection fluids off with clean water immediately after use.

Notes:

1. All information, specifications and illustrations within this manual are those in effect at the time of printing.
2. The manufacturer reserves the right to change or make improvements without notice and without incurring any obligation to make changes or add improvements to products previously provided.
3. Due regard must be paid to the safety of personnel. Testing should not create a hazard, particular attention being given to foreign matter located in discharge outlets.

Scope of this manual

This manual describes the Operation Service, Repair and Testing of the Pneumatech MGS LOX Tanks.

Pneumatech Medical Gas Solutions service contact

In the event of any queries or problems that cannot be resolved using information in this manual, please call:

44 (0) 1235 463051

Quote if possible, the:

- Product part number
- Lot/ Batch number
- Approximate date of purchase
- Apparent fault

Contents

LOX Tanks	1
Issue Record.....	ii
Introduction	ii
WARNINGS, CAUTIONS and NOTES	ii
Warnings!.....	ii
Cautions!.....	ii
Notes:	iii
Scope of this manual.....	iii
Pneumatech Medical Gas Solutions service contact	iii
Safety, Storage and Handling	vi
Identification.....	vi
Environmental Conditions	vi
1 Description	1
1.1 General Description.....	1
1.2 Schematic Diagrams	2
1.2.1 Safety Systems - Inner vessel	6
1.2.2 Safety Systems - Outer Vessel.....	6
1.2.3 Safety Systems - Piping.....	6
1.2.4 Pressure Building Function.....	6
1.2.5 Economizer Function - Pressure Reducer.....	6
2 Technical Specification	8
3 User Responsibility	9
4 Description of Symbols	9
5 Installation	10
5.1 General	10
5.1.1 Environmental conditions - Installation	10
6 Commissioning	12
6.1 Introduction	12
6.2 Initial filling with Oxygen	12
6.3 Pre-use Test.....	12
7 Operating Instructions	13
7.1 General Operating instruction.....	13
7.2 Pressure regulation	13
7.3 Withdrawal from cold converters	13
8 Maintenance	14
8.1 Introduction	14
8.2 Tools and equipment.....	14
8.3 Routine Inspection, Checks and Maintenance.....	14
8.3.1 Cleaning.....	14
8.3.2 Minimum Requirements.....	14
8.4 Pressure Regulators.....	15
8.4.1 Adjustment of pressure-building regulator	15
8.4.2 Adjustment of Economiser	16
8.4.3 Modification of compression zone by exchanging the springs	16
8.5 Liquid level indicator.....	17
8.6 Leak tests for instrumentation and piping	17
8.7 Re-evacuation	18
8.8 Evacuation	18

8.9 Replacement of outer vessel bursting disk	19
8.10 Taking out of service.....	20
8.10.1 Interruption of operation.....	20
8.10.2 Taking out-of-service	20
9 Fault Diagnosis	21
10 Recommended Spares	23

Figures

Figure 1-1; Schematic diagram 1	2
Figure 1-2; Schematic diagram 2.....	4
Figure 1-3; Schematic diagram 3.....	5
Figure 5-1; Lifting the tank from the horizontal position	11
Figure 8-1; Liquid level indicator	17
Figure 8-2; Evacuation closure tool	19
Figure 8-3; Evacuation connection	19
Figure 8-4; Replacement of outer vessel bursting disk.....	19

Tables

Table 1-1; Schematic diagram 1	3
Table 1-2; Schematic diagram 2	4
Table 1-3; Schematic diagram 3	5
Table 2-1; Technical Specification	8
Table 8-1; Inspection and Maintenance Schedule.....	15
Table 9-1; Failure to reach or maintain operating pressure	21
Table 10.2: Excessive tank pressure	21
Table 10.3: Erroneous or irregular contents gauge readings	22
Table 10.4: Main safety valve leaking	22
Table 10.5: Inner vessel bursting disk has burst.....	22
Table 10.6: Shut-off valves leaking.....	22
Table 10.7: Loss of vacuum	22
Table 10.8: Wrong or incorrect vacuum gauge reading.....	22
Table 10-1; Recommended Spares	23

Safety, Storage and Handling

All products are separately packaged and stored in under controlled conditions.

Identification

Pneumatech Medical Gas Solutions LOX Tanks can be identified by the machine number label fixed to the metal backplate.

Environmental Conditions

Pneumatech MGS LOX Tanks can be safely handled and stored under normal working and environmental conditions.

Adverse environmental conditions and harsh abrasives or chemicals may cause damage to the unit.

1 Description

The Pneumatech LOX tank are designed for the storage of low-temperature, liquefied oxygen.

1.1 General Description

LOX tanks are stationary, vacuum-insulated pressure vessels and consist of an inner and an outer pressure vessel.

The inner vessel, designed for the storage of low-temperature, liquefied gas, is manufactured out of cold-stretched material (stainless steel 1.4311 or 1.4301).

The outer vessel is manufactured out of carbon steel.

The space between the inner and outer vessel is filled with perlite, a grained insulation material and is evacuated up to a pressure of below 50 microns in a warm state (20°C). In addition, a molecular sieve ensures, by means of absorption, the long-term stability of the vacuum during the operation of the tank.

An automatic regulation system helps maintain the working pressure (pressure building function, see 1.2.4) and minimizes losses in case of lower withdrawal rates (economizer function, see 1.2.5).

The quality of the welded seams is checked by a leak test with helium, which also ensures long-term durability of the vacuum.

1.2 Schematic Diagrams

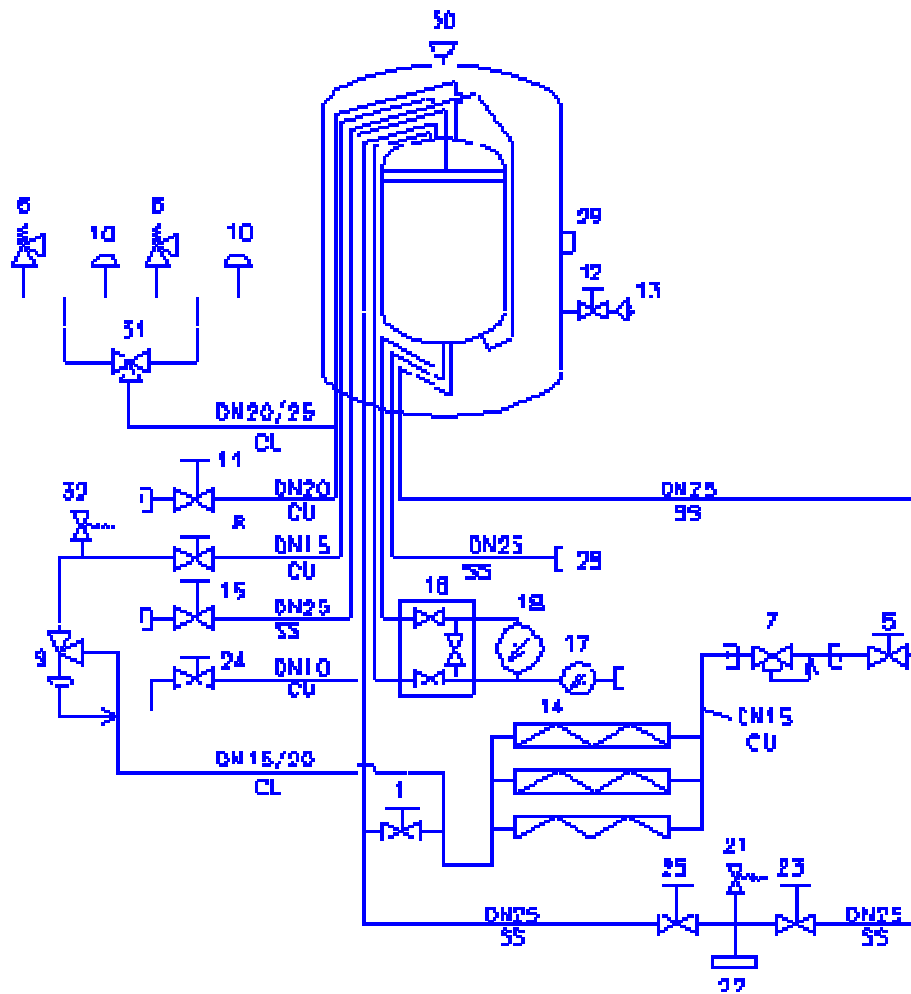

Figure 1-1; Schematic diagram 1

Table 1-1; Schematic diagram 1

Key	Description
2	Shut-off valve pressure building
3	Shut-off valve pressure building
6	Main safety valve
8	Shut-off valve - pressure reducing
9	Pressure reducing regulator
11	Vent valve
12	Vacuum probe valve
13	Vacuum probe
14	Pressure building coil
15	Liquid withdrawal valve
16	Three valve manifold
17	Pressure gauge
18	Liquid level gauge
22	Fill connection
23	Fill valve liquid phase
24	Fill try cock
25	Fill valve gas phase
28	Liquid withdrawal connection
29	Evacuation connection
30	Vacuum bursting disk outer tank
31	Change- over valve
32	Sectional safety valve
35	Purge valve
36	Speed shut off valve
37	Shut off valve process safety
38	Pressure reduction control - process protection

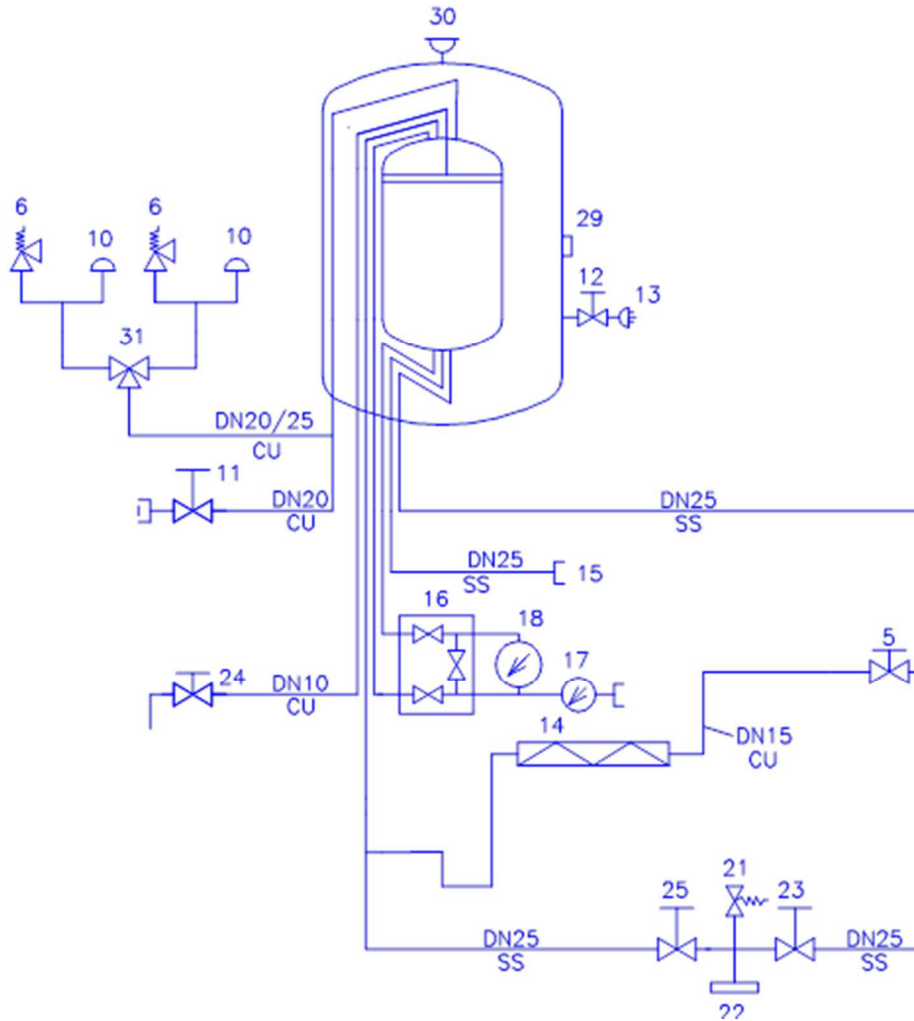

Figure 1-2; Schematic diagram 2

Table 1-2; Schematic diagram 2

Key	Description
5	Shut-off valve pressure building
6	Main safety valve
10	Inner tank bursting head
11	Vent valve
12	Vacuum probe valve
13	Vacuum probe
14	Pressure building coil
15	Liquid withdrawal valve
16	Three valve manifold
17	Pressure gauge
18	Liquid level gauge
21	Sectional safety valve
22	Fill connection
23	Fill valve liquid phase
24	Fill try cock
25	Fill valve gas phase
29	Evacuation connection
30	Vacuum bursting disk outer tank
31	Change-over valve

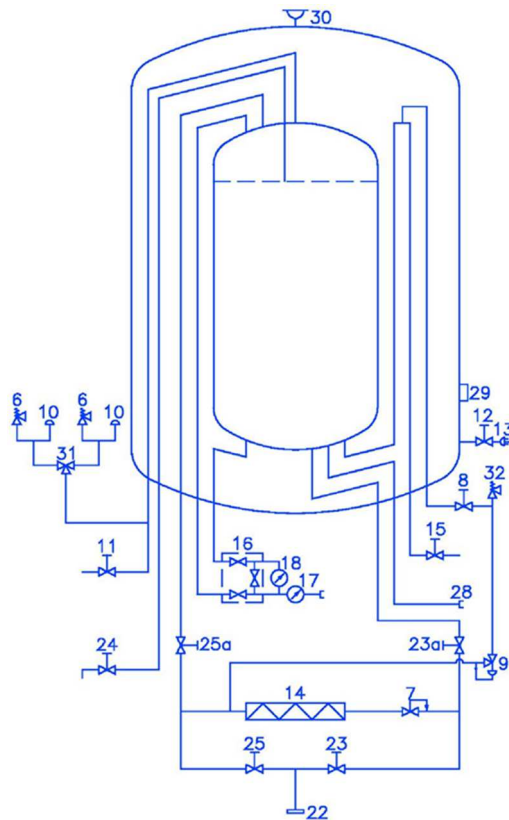

Figure 1-3; Schematic diagram 3

Table 1-3; Schematic diagram 3

Key	Description
6	Main safety valve
7	Pressure building regulator
8	Shut-off valve - pressure reducing
9	Pressure reducing regulator - economiser
10	Inner tank bursting head
11	Vent valve
12	Vacuum probe valve
13	Vacuum probe
14	Pressure building coil
15	Liquid withdrawal valve
16	Three valve manifold
17	Pressure gauge
18	Liquid level gauge
22	Fill connection
23	Fill valve - liquid phase
23a	Liquid phase service valve
24	Overflow valve
25	Fill valve - gas phase
25a	Gas phase service valve
28	Additional liquid withdrawal line
29	Evacuation connection
30	Vacuum bursting disk - outer tank
31	Changeover valve
32	Section safety valve

1.2.1 Safety Systems - Inner vessel

Two safety valves (no. 6) are connected to a change-over valve (no. 31) containing two interchangeable pressure chambers.

Depending on the respective position of the change-over valve, at least one safety valve is always connected to the gas phase of the inner vessel.

The release pressure of the safety valves must be equal to or smaller than the maximum permissible service pressure desired by the customer.

If a safety valve has to be exchanged, follow the manufacturer's instructions.

WARNING! Contact the manufacturer before exchanging one type of valve for another.

1.2.2 Safety Systems - Outer Vessel

The outer vessel is protected against internal overpressure by a vacuum bursting disk. The bursting disk will react at a pressure of a maximum 1.3 bar if, for example, gas streams into the vacuum space caused by a leakage in the inner vessel.

1.2.3 Safety Systems - Piping

Piping is protected against high pressures in those areas where liquid can be enclosed between two shut-off valves to cause a rise of pressure by evaporation.

WARNING! Check: Safety valves must be checked for correct function at regular intervals, in accordance with the appropriate regulatory requirement.

1.2.4 Pressure Building Function

If the service pressure falls below a set value the pressure building regulator opens and liquid gas streams into the pressure building coil.

Standard settings;

12 bar (18-18.5 bar tank)

15 bar (22 bar tank)

25 bar (37 bar tank)

Due to this increase of volume taking place through evaporation, the pressure rises up to the set value, and as a consequence the pressure-building regulator closes again to interrupt the pressure building process,

1.2.5 Economizer Function - Pressure Reducer

To improve the efficiency of the cold converter, the tank is equipped with an additional pressure reducing system.

This system works with a pressure reducing regulator (no. 9) which is installed in a connecting line between the gas phase and the highest point of the product withdrawal line.

If, due to a prolonged standstill, the pressure in the tank is above the adjusted opening pressure of the regulator, and if valve no. 8 is open, the economizer will open and opens the connection between gas phase and liquid phase.

In case of product withdrawal through valve no. 15, it will now be taken out of the gas reserve of the tank and this measure will result in a rapid reduction of pressure.

If the tank pressure is now below the opening pressure of the regulator, the economizer will close and withdrawal will be done out of the liquid phase, consequently with a smaller pressure drop.

The standard opening pressure is set 1 bar above the closing pressure of the pressure reducing regulator.

2 Technical Specification

Table 2-1; Technical Specification

Product name	
Physical Characteristics:	
Height	Varies with model
Width	Varies with model
Depth	Varies with model
Weight	Varies with model (2950 – 33000kg)
Capacity	Varies with model (3135 – 47500L)
Outer vessel	Carbon steel
Inner vessel	Stainless steel
Insulation	Vacuum/Perlite
Cleaning	For oxygen service
Coating – preparation	Blasted/ground [grade SA 2 ½ , DIN 559281]
Coating	Zinc primer, then polyurethane finish
Environmental Transport, Storage and Operating Conditions:	
Temperature transport/ storage	10 to 40°C
Humidity	10 to 95% R.H. Non-condensing
Air Pressure	Operating: 90 to 110 kPa
Mode of operation	Continuous (may be left on indefinitely)
Ingress Protection Class	IP4X (for indoor installation only)
Degree of mobility	Permanently installed
Performance:	
Operating pressure range	18.5 – 22.0 – 37.0 bar
Volumetric flow rate	TBA
Regulatory Classification:	
GMDN Code (Term)	36271 (Medical gas and vacuum supply systems)
EC MDD Classification	Class IIb
GHTF Classification	Class C

3 User Responsibility

This device has been built to conform to the specification and operating procedures stated in this manual and/ or accompanying labels and notices when checked, operated, maintained and serviced in accordance with these instructions.

To ensure the safety of this device, it must be checked and serviced to at least the minimum standards laid out in this manual. A defective or suspected defective product must not be used under any circumstances.

The user must accept responsibility for any malfunction which results from non-compliance with the servicing requirements detailed in this manual. Additionally, the user must accept responsibility for any malfunction which may result from misuse of any kind, or non-compliance with other requirements detailed in this manual.

Worn, broken, distorted, contaminated or missing components must be replaced immediately. Should such a replacement repair be necessary, it is recommended that a request for service advice be made to the nearest Pneumatech Medical Gas Solutions Service Centre.

This device and any of its constituent parts must be repaired only in accordance with written instructions issued by Pneumatech MGS and must not be altered or modified in any way without the written approval of Pneumatech MGS.

The user of this equipment shall have the sole responsibility for any malfunction which results from improper use, maintenance, repair, damage or alteration by anyone other than Pneumatech MGS or their appointed agents.

4 Description of Symbols

WARNING! Indicates a potentially hazardous situation which, if not avoided, could result in personal injury to the user or others.

CAUTION! Indicates a potentially hazardous situation which, if not avoided, could result in damage to the device or property.

Note: Emphasises points to achieve more convenient or efficient use of the device.

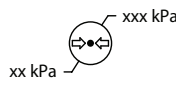
 Ambient pressure range

 Ambient humidity range

 Ambient temperature range

 Consult accompanying documents

 Service due date

5 Installation

Pneumatech Medical Gas Solutions LOX Tanks should only be installed, commissioned, and maintained by technicians who are suitably trained with piped medical gas systems, and who are fully conversant with the contract specifications and safety procedures.

5.1 General

5.1.1 Environmental conditions - Installation

Warning! Keep all components dry and clean during installation.

Pneumatech Medical Gas Solutions LOX Tanks can be safely handled and stored under normal working and environmental conditions.

Adverse environmental conditions and harsh abrasives or chemicals may cause damage to the unit.

Warning! Install the system as directed by the site engineer, for the optimum position. Check that the specified pressure safety valves, non-return valves and regulators have been fitted and verify the valves are certified to operate in accordance with the contract specification and conform to BS 6759: part 2 1984.

Warning! Oxygen service - Danger of fire and explosion!

Note: Take care when brazing into the gas pipeline, to prevent damage to the regulator due to heat transfer. Pneumatech Medical Gas Solutions will not accept responsibility for damage caused during installation.

Transport

The tanks are delivered from the factory with an air load of approximately 1.5 bar in order to prevent the penetration of air humidity. The humidity of the air can lead to ice formation that could harm the installation function.

Maintain pressure until the tank is set up for operation!

- Check the tank visually in order to locate any damage incurred during transport or lifting.

- Vacuum check:

The tank vacuum will be checked prior to leaving our plant. See chapter „Maintenance

Installation site

1. Works at the vessel (e.g. service, installation, commissioning, and placing out of operation) must only be carried out by competent personnel!
2. Please comply with local regulations for the installation and operation of pressure vessels.
3. Safety valves must be inspected at regular intervals for correct function, in accordance with respective directives.
4. Locate the tank only in the open air! If tank is placed inside, please observe special instructions. Contact the manufacturer.
5. Tanks for the storage of liquid gases shall not be placed in, or in the direct proximity of, passages or staircases.

Selection of Installation Site - Checklist

1. Check for adequate access!
2. Check for escape routes!
3. There must be no entrances to locations situated below the tank within a radius of 5 m.
4. The floor must not be made out of combustible material (e.g. asphalt).
5. Controls and fittings must be operable from a fixed stand
6. Foundations: build concrete foundations if necessary. Plans are available from the manufacturer.

Installation procedure

1. Lifting the tank from the horizontal position

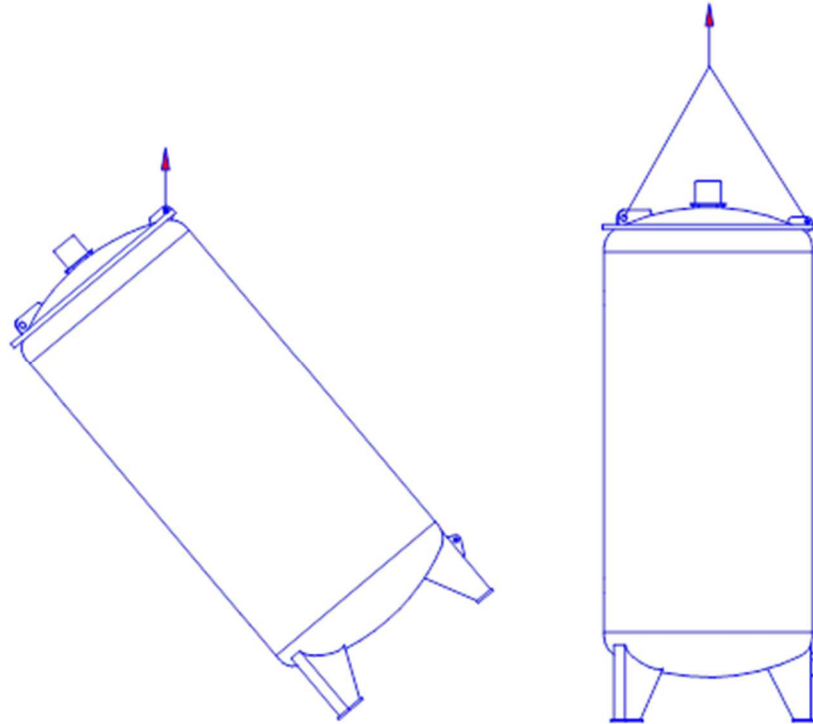

Figure 5-1; Lifting the tank from the horizontal position

6 Commissioning

6.1 Introduction

Commissioning is carried out in full after initial installation, after a major component change, and as part of a planned preventative maintenance programme. The object of commissioning is to ensure that all components are serviceable. Personnel carrying out the following commissioning procedure must be qualified and fully conversant with the information contained in this manual.

Pneumatech Medical Gas Solutions LOX Tanks are tested and certified prior to despatch from the manufacturing plant.

6.2 Initial filling with Oxygen

Initial filling, or filling after a prolonged standstill.

Tank is completely empty, inner vessel is 'warm'.

Procedure

1. Close all valves except the valves on the contents gauge
2. Connect the filling pipe to the fill connection
3. Open valves 23 and 24
4. Open the valve of the tanker

Filling is started

- Watch the manometer. Tank pressure must always be lower than filling pressure!
 - When the tank is filled to three-quarters full, open and watch the overflow valve, 24.
 - When liquid spurts out at the overflow valve, the tank is full
5. Close the tank fill valve.
 6. Close valves 24 and 11
After a few minutes the residual liquid in the fill pipe will have vaporized
 7. Close valve 23
 8. Relieve the pressure in the fill pipe

6.3 Pre-use Test

Note: Due regard must be paid to the safety of personnel. Testing should not create a hazard, particular attention being given to foreign matter located in discharge outlets.

7 Operating Instructions

7.1 General Operating instruction

In case of a prolonged standstill or withdrawal quantities that are too small, depending on the filling temperature and on the permissible service pressure, you must choose a lower filling level. Pressurisation through normal evaporation will be slowed down if the gas space increases.

7.2 Pressure regulation

Pressure regulation is by means of the liquid phase fill valve (23) and the gas phase fill valve (25)

Pressure drops when filling is complete through the gas phase fill valve (25), and rises when filling takes place through the liquid phase fill valve (23).

1. When the tank is filled to three-quarters full, open and watch the overflow valve, 24.
2. When liquid spurts out at the overflow valve, the tank is full
3. Close the fill valve on the tanker
4. Close the liquid phase valve (23) and the overflow valve, 24
5. After a few minutes the residual liquid in the fill pipe will have vaporized
6. Close valve 25
7. Relieve the pressure in the fill pipe
8. Fill the tank only up to 90%

Note: Fill the tank if the level falls to a quarter full.

7.3 Withdrawal from cold converters

After opening the liquid withdrawal valve no. 15, liquid gas will flow into the distribution line or through the clip-on vaporizer. The pressure building system works automatically if valves no. 1 and 5 are open, and maintains the necessary working pressure.

Readjust as per section 8.4, 'Pressure regulators'.

For maximum liquid withdrawal quantities for each type of tank, please refer to the technical datasheet for this product.

8 Maintenance

8.1 Introduction

Pneumatech MGS LOX Tanks are designed to operate with the minimum of maintenance, however regular routine minor maintenance operations are recommended to prove the system integrity. Maintenance operations are carried out in accordance with the planned preventative maintenance contract purchased by the customer.

Maintenance engineers must fully understand the LOX Tank and must be conversant with the information contained in this manual.

Service and Maintenance is limited to replacement of worn or damaged components.

Warnings! Use of sub-standard or inappropriate parts and materials may damage the equipment and invalidate the warranty. Only use genuine Pneumatech Medical Gas Solutions spare parts.

Warnings! Obtain a work permit before commencing any work on medical gas equipment.

8.2 Tools and equipment

No special tools are required, however all common hand tools used must be clean, completely free of oil and grease and checked for serviceability before commencing maintenance procedures.

All necessary spare parts must be obtained before commencing work.

8.3 Routine Inspection, Checks and Maintenance

8.3.1 Cleaning

The use of abrasive or solvent based cleaning solutions is not recommended.

Cleaning external surfaces - use a damp cloth only. Mild soap solution may be used but detergent/surfactant solutions are not recommended.

Do not use any phenol or halogen based disinfectants or agents that release chlorine or oxygen.

8.3.2 Minimum Requirements

Minimum requirements for routine inspections, checks and maintenance are given in *Table 8-1* and must be observed in full to ensure continued safe operation of the system.

Table 8-1; Inspection and Maintenance Schedule

5 Yearly					◆			◆
Annually					◆			◆
Quarterly		◆			◆			
Monthly							◆	
Commissioning		◆	◆	◆	◆	◆		◆
Actions	Inspection, Checks and Tests:	Ambient temperature	Suitability of location	Adequate room ventilation	Adequate access for maintenance	Visually inspect the unit for damage	Planned Preventative Maintenance:	Complete Commissioning Procedure

8.4 Pressure Regulators

8.4.1 Adjustment of pressure-building regulator

Note: Refer to section 1.2.4.

1. Set the service pressure 0.1 bar above the desired opening pressure.

For a higher service pressure:

Open valves no. 11 or 24 and release pressure.

For a lower service pressure:

After loosening the locknut on the regulator, turn the pressure screw into the casing (approximately 1 bar per turn).

2. Check the reading on the pressure gauge.

Adjustment

1. Close valve no. 23a.
2. Loosen the locknut on the regulator, screw out the pressure adjustment screw a few turns.

3. Release the pressure in the line between the regulator and valve no. 23a by carefully loosening the threaded joint.
4. If gas is still being discharged, screw out pressure screw on the regulator until gas flow is interrupted.
5. Turn in the pressure screw slowly until the regulator starts to open.

Check

1. Release the pressure in the tank by opening valve no. 24.
2. If the pressure falls below the set pressure the regulator will open completely or will start to open when the requested pressure is reached.
3. Close valve no. 24.
4. Refit the locknut.
5. Fit the threaded joint between regulator and valve and reopen valve no. 23a.

8.4.2 Adjustment of Economiser

Set the service pressure 0.1 bar above the desired opening pressure.

For a higher service pressure:

Open valves no. 11 or 24 and release pressure.

For a lower service pressure:

After loosening the locknut on the regulator, turn the pressure screw into the casing (approximately 1 bar per turn).

Observe the reading on the pressure gauge!

Adjustment

1. Close valves no. 25a, 23a, and 8 and screw out the sectional safety valve no. 32.
2. Loosen the locknut on the regulator.
3. Carefully open valve no. 25.
4. Stop the gas stream by screwing in the pressure screw.
5. Unscrew the pressure screw until the regulator just begins to open.
6. Refit the locknut, re-install safety valve no. 32, and fully re-open valves no. 25a, 23a, and 8.

8.4.3 Modification of compression zone by exchanging the springs

The range delivered by the factory setting can be modified by fitting an exchange set of springs and membranes, as follows:

1. Remove the valves from the unit.

Caution! Prior to removal, release the pressure from the regulators.

Pressure building regulator (no. 7):

Close valves no. 25a and 23a, and the threaded joint, until pressure is released.

Pressure reducing regulator (no. 9):

Close valves no. 25a, 23a, and 8, then loosen safety valve no. 32, until pressure is released.

2. Fix the casing in a vice, do not overtighten the clamp. Use a ring spanner.
3. Relieve the set value springs completely by loosening the adjusting screw.
4. Unscrew the casing with the spanner and remove the components. Take care that the membranes and cones are not misplaced.
5. Insert the exchange set of springs to achieve the required set value range.
6. Reassemble the spring, globe, and membrane disk.
7. Put the required number of diaphragm membranes on the membrane disk. Note that **number of membranes only changes for Samson-type regulators**
Fit a new PTFE gasket to the casing.
Carefully put the casing onto the bonnet and screw in (tighten to 250 Nm).

8.5 Liquid level indicator

Measurement principle: Differential pressure measurement between the pressure in the gas chamber and the pressure increased by the head of liquid at the lowest point in the tank.

Measuring instrument: SAMSON Media 5 or Media 6.

Scale: Triple scale for oxygen

Units: Litre, m³, or Nm³

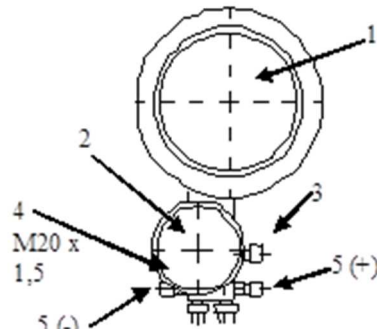

Figure 8-1; Liquid level indicator

1. Differential pressure indicator
2. Pressure gauge
3. Bypass valve
4. Test connection
5. Shut-off valve

Zero adjustment of the liquid level indicator

1. Close the shut-off valves on the instrument line at the three-valve manifold.
2. Open the bypass valve.
Due to the pressure balance taking place in both pressure chambers, the pressure gauge should now read zero.
3. If required, turn the screw to adjust to zero.
4. Close the bypass valve.
5. Slowly open shut-off valves of the instrument line.

Warning! Special equipment is required for adjustment of differential pressure. Please contact the manufacturer.

8.6 Leak tests for instrumentation and piping

1. Check instrumentation and threaded joints as well as any pipe connections regularly, especially during the first weeks and months of service!
2. Due to changing temperature differences between ambient and cryogenic state, threaded joints and valve packing can loosen.
3. Important. Leaks are audible and can be identified by icing.
4. Leaking valves building a connection between liquid phase and gas phase, can lead to high pressure build-up. In warmer environments, wetted tubes indicate smaller leaks.
5. Tubes with no flow of gas or liquid must be free of ice!
6. In case of icing or humidity, check the shut-off valves and tighten the threaded joints.
7. Smaller leaks can be found by brushing with a foaming solution.

8.7 Re-evacuation

Note: Frequent vacuum measurements are not advisable. Each time the vacuum valve (no. 12) is opened, the vacuum deteriorates.

Measurement of the vacuum:

Measuring point: Vacuum gauge tube no. 13
Type: Hastings Raydist DV-6R
Measuring device: Hastings Raydist ATV-4
Measurement devices are available from the manufacturer.

Note: After each measurement the valve on the vacuum gauge tube no. 12 must be closed carefully!

8.8 Evacuation

Heating the empty inner vessel:

1. Close valves no. 8 and 25.
2. Let warm nitrogen gas stream through the vessel.
Inlet: vent valve no. 11
Outlet: through valve no. 23 at the fill connection no. 22
3. Close valves no. 11 and 23, and open valve no. 8 when the gas temperature at the outlet is > -50°C.
Caution! Maintain a pressure of approximately 1 bar in the inner vessel.

Remove the evacuation plug as follows:

1. Heat the adhesive epoxy with a hot air blower.
2. Screw in an M16 screw and remove the plug.
3. Remove the O-ring.
4. Clean the adapter socket and plug of any residual adhesive.
5. Lubricate the new O-ring with vacuum grease and insert into the groove in the socket.
Install the cleaned plug into the vacuum closure tool.
6. Connect the vacuum tube to the vacuum closure tool and fit the device to the evacuation plug.
Tighten the clamp.
7. Evacuate to < 100 micron.
The evacuation time can be considerably reduced by heat supply (through valves no. 11 and 23) with warm and dry nitrogen gas.
8. To insert plug in the socket, firmly press in the piston of the closure tool.
Then remove the closure tool.
9. Heat the socket to approximately 100°C and seal by means of Crest sealant (50/50 mixture).
Sealing compound can be obtained from the manufacturer

Evacuation closure tool

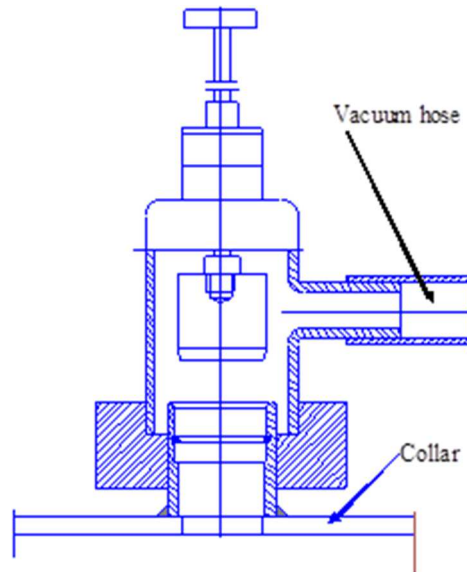

Figure 8-2; Evacuation closure tool

Evacuation connection

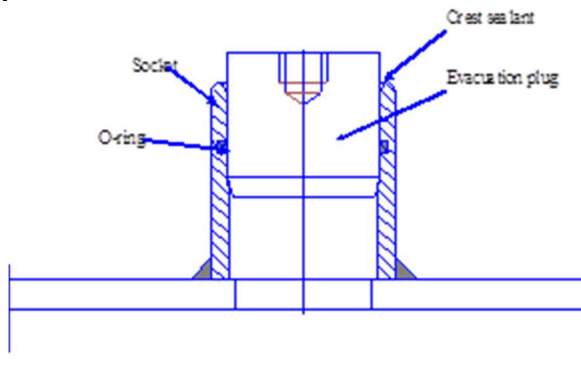

Figure 8-3; Evacuation connection

8.9 Replacement of outer vessel bursting disk

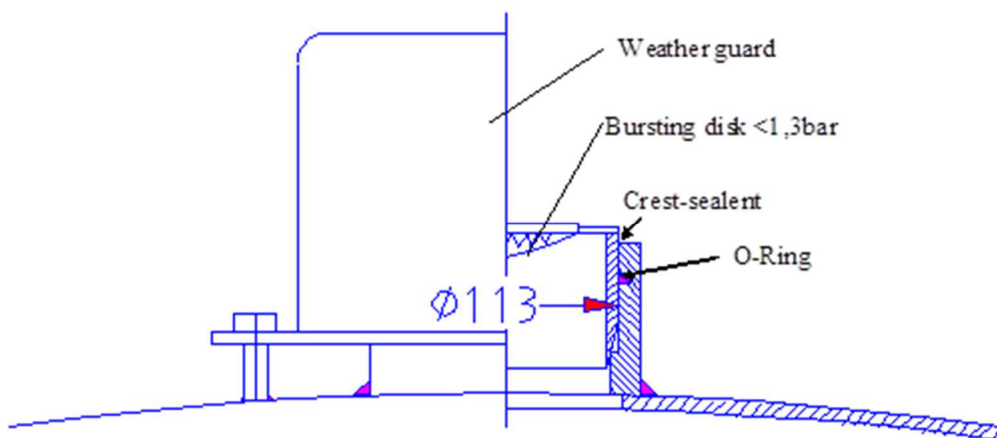

Figure 8-4; Replacement of outer vessel bursting disk

Visual inspection

1. Remove the weather guard and inspect the disk visually for ruptures or corrosion. If there is any visible damage the bursting disk must be renewed.
2. Take the vessel out of operation.
3. If the vacuum is not completely broken, break it by means of nitrogen gas through valve no. 12.
4. Heat the epoxy adhesive and remove the bursting disk.
5. Remove the O-ring and clean any excessive adhesive from the socket.
6. Lightly lubricate the O-ring with vacuum grease and insert in the socket groove of the adapter. Clean any excessive grease from the adapter socket.
7. To install the bursting disk, push firmly down by hand.
8. Heat the outside of the socket to approximately 100°C and seal with Crest sealant (50/50 mixture).
9. Then evacuate the vessel, as described in section 8.8.

8.10 Taking out of service**8.10.1 Interruption of operation**

In case of a prolonged standstill or too small withdrawal quantities depending on the filling temperature and on the permissible service pressure, you must choose a lower filling level. Pressurisation through normal evaporation will be slowed down if there is a bigger gas space.

8.10.2 Taking out-of-service

The vessel must always be filled with dry gas with a slight overpressure of approximately 1.5 bar to prevent the penetration of humid air. All valves and connections must be closed.

9 Fault Diagnosis

There are a number of faults that can be diagnosed on Pneumatech Medical Gas Solutions SC Tanks.

These are relatively simple to remedy, without replacing expensive regulator assemblies.

The majority of faults can be avoided by undertaking a regular planned maintenance routine, carried out by a competent person.

Note: Failure through misuse or abuse is usually not repairable, and is not covered by the manufacturer's warranty.

Safety instructions

1. Any work on the tank such as servicing, installation, commissioning and decommissioning must only be carried out by competent, trained personnel!
2. Never allow inflammable material (wood, rubber, clothes, and asphalt) to come into contact with oxygen.
3. Inflammable materials soaked in oxygen are explosive when ignited!
4. Rooms which are in danger of being penetrated with gases must be ventilated before entering!
5. Danger of fire (oxygen)
6. In the area surrounding oxygen tanks, smoking and open fires are strictly forbidden.
7. Do not allow liquid, low-temperature gases to come into contact with unprotected parts of the human body.
8. Always wear suitable protective clothes: gloves, protective glasses, bulky clothes and trousers which overlap shoes.
9. In case of skin or eye contact with low-temperature gases, treat any affected areas with large quantities of cold water and cold compresses immediately, and seek medical advice!

Table 9-1; Failure to reach or maintain operating pressure

Possible Cause	Remarks/rectification action
Excessive withdrawal	Increase capacity of pressure building coil
Liquid level too low	Refill tank
Leaks on outer piping	Seal
Safety valves do not close	Replace
Strainer at inlet of pressure building regulator clogged	Clean
Improper adjustment of regulator, or regulator defective	Correct adjustment or replace regulator - see Maintenance section
Withdrawal rate too low	See 'Withdrawal' section

Table 10.2: Excessive tank pressure

Possible cause	Remarks/rectification action
Prolonged standstill	See 'Re-evacuation' section
Improper filling	See 'Filling' section
Inadequate vacuum	See Maintenance and Filling sections for higher pressure

Table 10.3: Erroneous or irregular contents gauge readings

Possible cause	Remarks/rectification
Bypass valve not closed or leaking	Close or replace
Wrong adjustment	Readjust
Leaking in differential pressure pipes or connections	Seal
Gauge damaged or leaking	Replace, or return to manufacturer for repair

Table 10.4: Main safety valve leaking

Possible cause	Remarks/rectification
Dirt or ice under disk cone	Replace

Table 10.5: Inner vessel bursting disk has burst

Possible cause	Remarks/rectification
Bursting disk with too low pressure	Replace
Corrosion or material fatigue	Replace

Table 10.6: Shut-off valves leaking

Possible cause	Remarks/rectification
Valve seat loose	Tighten
Damaged seat or cone	Replace valve

Table 10.7: Loss of vacuum

Possible cause	Remarks/rectification
Leak on vacuum bursting disk	Replace - see 're-evacuation' section
Leaking measuring socket	Seal - see 're-evacuation' section

Table 10.8: Wrong or incorrect vacuum gauge reading

Possible cause	Remarks/rectification action
Gauge not properly calibrated	Calibrate
Batteries have no charge	Replace
Defective vacuum gauge tube	Replace

10 Recommended Spares

Table 10-1; Recommended Spares

Item	Description	Part Number	Number of Panels Installed		
-					
-					
-					
-					
-					
-					

Spares Department:

T: 44 (0) 1235 463053

F: 44 (0) 1235 463011

spares@p-mgs.com

Pneumatech Medical Gas Solutions

Unit 18 Nuffield Way

Abingdon

Oxfordshire

OX14 1RL UK

Sales

T: 44 (0) 1235 463010

F: 44 (0) 1235 463011

sales@p-mgs.com

Spares

T: 44 (0) 1235 463053

F: 44 (0) 1235 463011

spares@p-mgs.com

Service

T: 44 (0) 1235 463051

F: 44 (0) 1235 463011

service@p-mgs.com

Document Ref. 8102341086 Issue 00

Revision issue date: November 2015

© Atlas Copco 2015. All rights reserved.

Company Reg. Office: Swallowdale Lane, Hemel Hempstead, Hertfordshire HP2 7EA, UK

