

Medical Air Plant – HTM2022 & HTM02-01

Plant Systems

Installation, Operation and Maintenance Manual

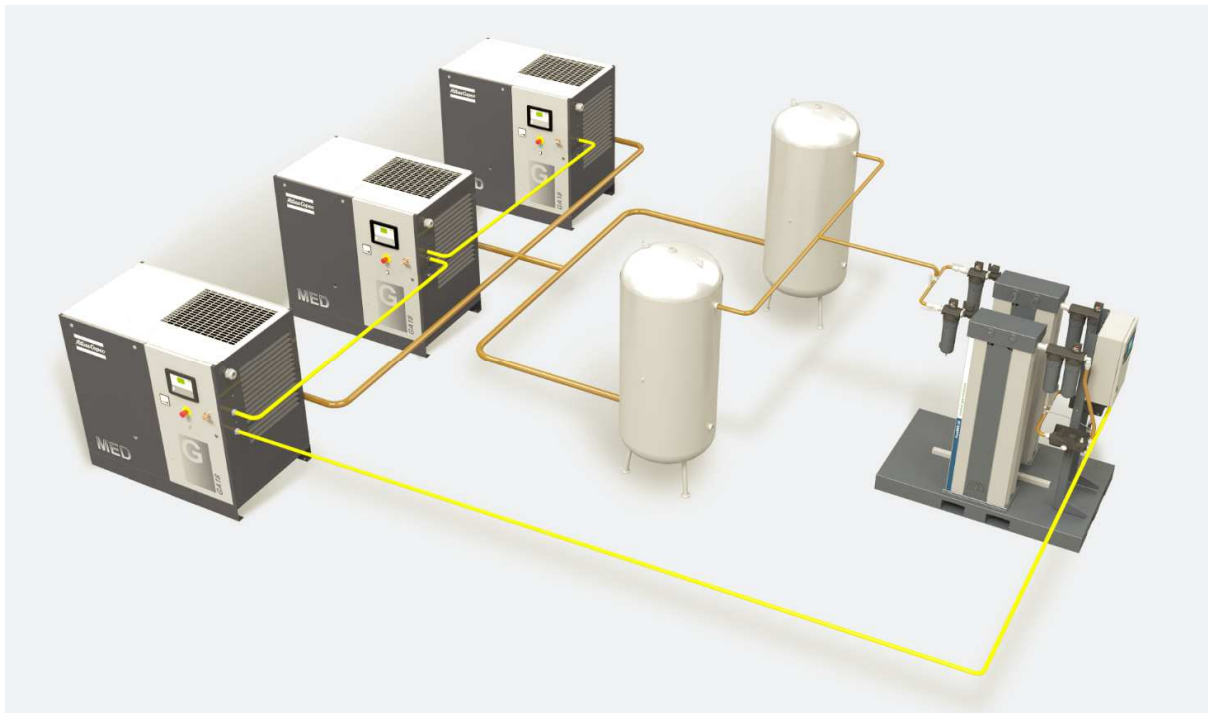

Published by Pneumatech Medical Gas Solutions

All possible care has been taken in the preparation of this publication, but Pneumatech Medical Gas Solutions accepts no liability for any inaccuracies that may be found.

Pneumatech Medical Gas Solutions reserves the right to make changes without notice both to this publication and to the product which it describes.

Copyright © 2015 Atlas Copco All rights reserved.

No part of this publication may be reproduced, transmitted, transcribed, or stored in a retrieval system or translated into any human or computer language in any form or by any means without the prior permission of Pneumatech Medical Gas Solutions.



Important

Personnel must make themselves familiar with the contents of this manual and the function of the unit before installing, operating or maintaining any Medical Air Plant.

Information contained in this manual is correct at the date of publication. The policy of Pneumatech Medical Gas Solutions is one of continuous product improvement. Pneumatech Medical Gas Solutions reserves the right to make changes that may affect instructions in this manual without prior notice.

For any enquiry regarding the servicing or repair of this device, contact the nearest accredited Pneumatech Medical Gas Solutions agent, or communicate directly with:



Pneumatech Medical Gas Solutions
Unit 18 Nuffield Centrum
Nuffield Way
Abingdon
Oxfordshire
OX14 1RL
UK

<http://www.p-mgs.com>

Sales

Tel: 44 (0) 1235 463010
Fax: 44 (0) 1235 463011
sales@p-mgs.com

Spares

Tel: 44 (0) 1235 463053
Fax: 44 (0) 1235 463011
spares@p-mgs.com

Service

Tel: 44 (0) 1235 463051
Fax: 44 (0) 1235 463011
service@p-mgs.com

Any complaints about the products or services provided by Pneumatech Medical Gas Solutions, please give as much of the following information as possible:

Product Part Number
Lot/ Batch Number
Approximate date of purchase
Apparent fault.

Complaints

T: 44 (0) 1235 463010
F: 44 (0) 1235 463011
complaints@p-mgs.com

Issue Record

Issue No.	Reason for Change	Pages affected	Date
00	First release	All	2015

Introduction

This manual contains information needed to install, operate and maintain the Pneumatech Medical Gas Solutions (Pneumatech MGS) Medical Air Plant.

The contents of this manual are intended to be read and used by suitably qualified personnel.

AC input power connection

Electrical supply requirements vary with different compressor models. Incoming wiring must include neutral and earth.

The following Warnings, Cautions, and Notes must be read and understood before using Pneumatech Medical Gas Solutions Air Plant.

WARNINGS, CAUTIONS and NOTES

The following Warnings, Cautions, and Notes must be read and understood before using the Medical Air Plant.

Warnings!

Warnings tell you about dangerous conditions that could lead to death or serious injury to the user that can occur if you do not obey all of the instructions in this manual.

WARNING! Read through this entire instruction manual before using or showing others how to use this equipment. Attempting to use this device without a thorough understanding of its operation may result in patient or user injury.

WARNING! Wear protective gloves when handling oily components.

WARNING! The interlock isolator on the Pump Starter Panel must be isolated (switched off) and locked in the off position before accessing compressor electrical compartments or mechanical drives.

WARNING! Wear protective gloves when handling air compressor internal components. Components upstream of and including the after cooler may reach temperatures of over 100°C during operation.

WARNING! Operating the medical air system in an ambient temperature greater than 35°C (95°F) will affect the performance of the desiccant dryer and may compromise the quality of the delivered air.

WARNING! Do not attempt to modify this device in any way not strictly described within this manual. Failure to observe this may result patient or user injury or death.

WARNING! Medical air plant must be protected from access by unauthorised personnel.

WARNING! Beware of sudden loud noises – compressors may start automatically and dump valves rapidly exhaust pressurised air during dryer changeover.

WARNING! Ear defenders (hearing protection) may be needed, especially during maintenance if acoustic enclosures are removed.

WARNING! The surfaces of the pumps and components connected to them reach high temperatures when operating for long periods.

WARNING! Pump starter panels are supplied with dangerous voltages. The mains supply must be isolated (switched off) and locked in the off position before attempting to access live components in the pump starter panel.

Cautions!

Cautions tell you about dangerous conditions that can occur and cause damage to the equipment if you do not obey all of the instructions in this manual.

CAUTION! Use of sub-standard or inappropriate parts and materials may damage the Manifold System and invalidate the warranty. Only use genuine Pneumatech Medical Gas Solutions spare parts.

CAUTION! Do not stand on a compressor.

CAUTION! Always open valves slowly.

CAUTION! Be careful not to over-torque face seal fittings.

CAUTION! Only use leak detection fluids that are compatible with the materials being tested.

CAUTION! Always wash leak detection fluids off with clean water immediately after use.

CAUTION! Do not cover or occlude compressor ventilation grills.

CAUTION! Before starting any motor, remove all transport bolts inside compressor canopies and check all oil levels. Refer to the manufacturers specific instructions provided with the compressor.

CAUTION! Never close the valve on the compressor outlet without first electrically isolating the compressor. If the compressor is run with the outlet valve closed it will vent oil mist through the relief valve on the oil separator.

CAUTION! The control system contains static sensitive electronic components. Do not touch without appropriate precautions. Always wear an anti-static wrist strap when touching printed circuit board assemblies. Failure to do so may result in irreparable damage to electronic components and will invalidate the warranty.

Notes:

1. Spectrographic oil analysis is recommended to monitor lubrication efficiency and to extend the life of compression elements.
2. All information, specifications and illustrations within this manual are those in effect at the time of printing.

3. The manufacturer reserves the right to change or make improvements without notice and without incurring any obligation to make changes or add improvements to products previously provided.

Abbreviations used

The following abbreviations are used in this manual:

Abbreviation	Full name
MGS	Medical Gas Solutions
kPA	Kilopascal
R.H.	Relative Humidity
IP4X	Ingress Protection Class (for indoor installations only)
DIN	Deutsches Institut für Normung
HTM	Health Technical Memorandum
LED	Light Emitting Diode
CAN	Controller Area Network
LAN	Local Area Network
ppm	Parts per million
EFL	Emergency forced local
°C	Degrees Celsius
VSD	Variable speed drive
ARAF	Automatic start after power failure
h	Hours
IO	Input/Output
AC	Alternating Current
V	Volts
Hz	Hertz

Scope of this manual

This manual describes the Operation Service, Repair and Testing of the Pneumatech MGS Medical Air Plant.

Pneumatech Medical Gas Solutions service contact

In the event of any queries or problems that cannot be resolved using information in this manual, please call:

44 (0) 1235 463051

Quote if possible, the:

- Product part number
- Lot/ Batch number
- Approximate date of purchase
- Apparent fault

Contents

Medical Air Plant – HTM2022 & HTM02-01	1
Issue Record.....	2
Introduction.....	2
AC input power connection.....	2
WARNINGS, CAUTIONS and NOTES	2
Warnings!.....	2
Cautions!.....	3
Notes:.....	3
Abbreviations used.....	4
Scope of this manual.....	4
Pneumatech Medical Gas Solutions service contact.....	4
Safety, Storage and Handling	7
Safety Features.....	7
Other Essential Features.....	7
Environmental Conditions.....	7
1 Introduction	8
1.1 Intended Use.....	8
1.2 Plant System.....	9
1.2.1 Major components.....	10
2 Technical Specification	12
3 User Responsibility	12
4 Description of Symbols	14
5 Installation and Commissioning	16
5.1 Installation.....	16
5.1.1 Environmental Conditions.....	16
5.1.2 Electrical Supply.....	16
5.1.3 Components.....	16
5.1.4 Plant Installation.....	16
5.2 Commissioning.....	17
5.2.1 Pre-test checks.....	17
6 Operating Instructions	18
7 Maintenance	19
7.1 Introduction.....	19
7.2 Air receiver maintenance.....	19
7.3 Pressure relief valves.....	19
7.4 Solenoid valve maintenance.....	19
7.5 Regulator maintenance.....	20
8 Recommended Spares	21

Figures

Figure i; Identification Label	7
Figure 1-1; Medical Air Plant – general view	8
Figure 1-2; Medical Air Plant – General flow diagram	9

Tables

Table 1-1; Specifications of Delivered Air	11
Table 2-1; Technical Specification	12

Safety, Storage and Handling

Safety Features

The duplex filter layout allows the elements to be replaced without shutting down the system.

Other Essential Features

Storage

Pneumatech Medical Gas Solutions Medical Air Plant can be safely handled and stored under normal working and environmental conditions.

Adverse environmental conditions and harsh abrasives or chemicals may cause damage to the unit. All products are separately packaged and stored under controlled conditions.

Identification

The Pneumatech MGS Medical Air Plant is identified by the machine number, printed onto a label fixed to the side of the control box and details:

- Model number.
- Reference number.
- Serial number.
- Compressor/ Pump supply voltage and frequency.
- Dryer/ Filter Module reference number.

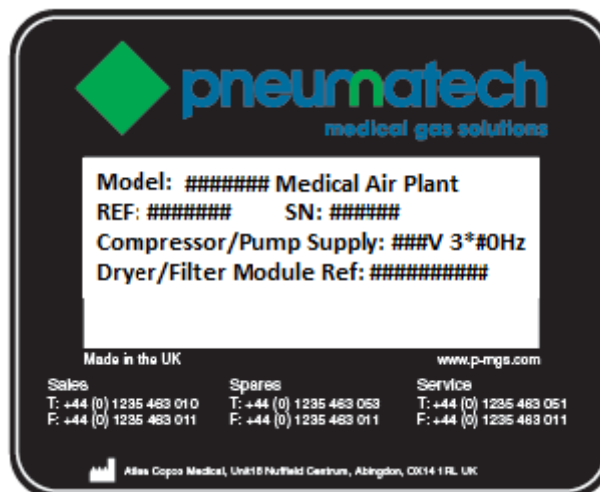

Figure i; Identification Label

Environmental Conditions

Pneumatech MGS Medical Air Plant can be safely handled and stored under normal working and environmental conditions.

Adverse environmental conditions and harsh abrasives or chemicals may cause damage to the unit.

1 Introduction

1.1 Intended Use

The Pneumatech Medical Gas Solutions Medical Air Plants are intended to continuously deliver medical quality air to a healthcare facilities medical air pipeline system.

Features:

1. Oil flooded Rotary screw, reciprocating compressors and oil free reciprocating, scroll or claw.
2. Plant available for operation from 420 kPa, depending on model.
3. Automatic control system ensures economical operation, no day to day input required.
4. Monitoring includes 'plant to alarm interface and indicator'.
5. Multi-purpose test point fitted adjacent to plant/ pipeline interface.
6. High efficiency filter/ dryer units give maximum output and ensure purity of delivered air.
7. Quick and simple installation.
8. Modular components for on site flexibility.

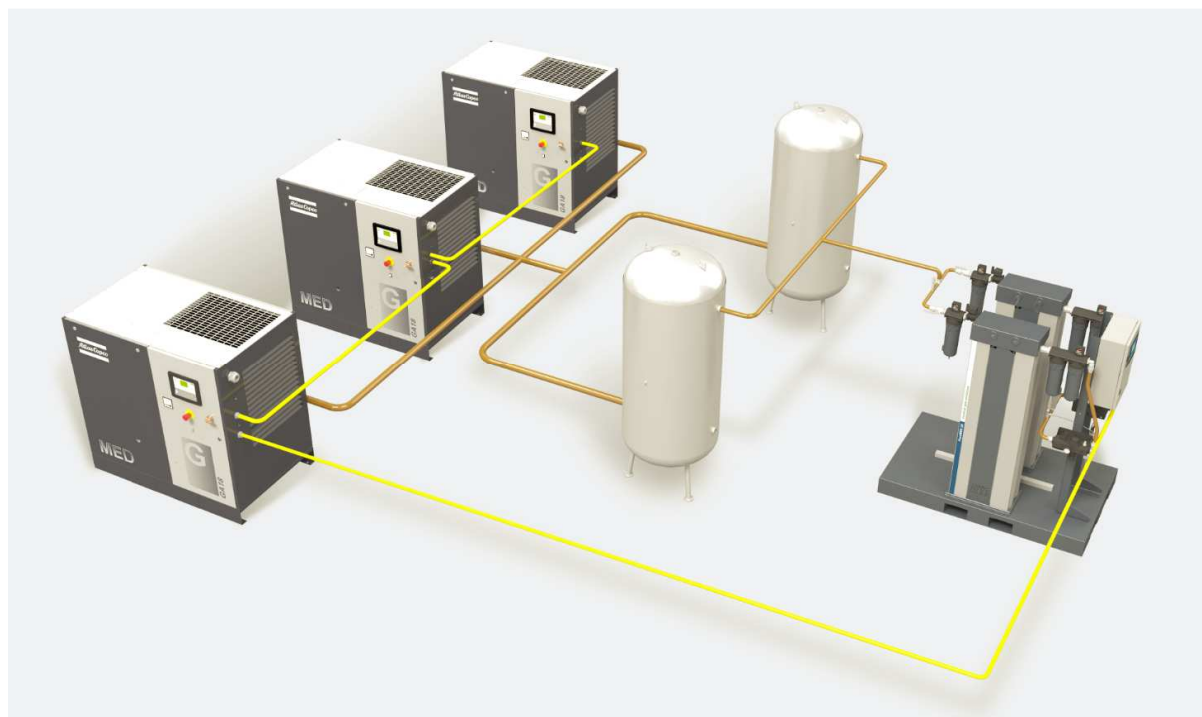

Figure 1-1; Medical Air Plant – general view

1.2 Plant System

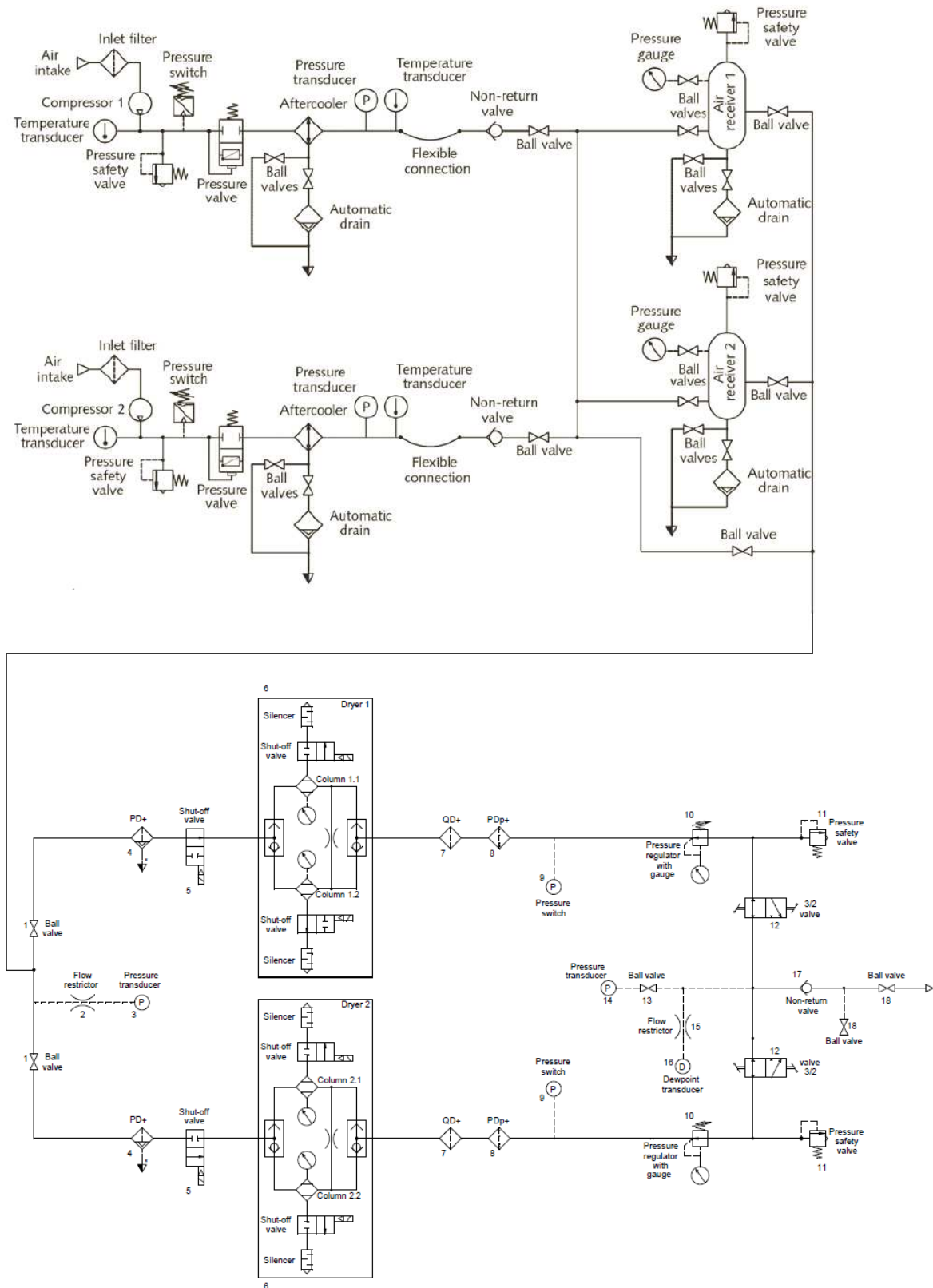

Figure 1-2; Medical Air Plant – General flow diagram

1.2.1 Major components

The Pneumatech Medical Gas Solutions Medical Air Plant consists of the following major components:

- Two or more compressors, up to a maximum of six, any of which can be selected as duty compressor
- Pump monitors which indicate the status of their respective compressors.
- Air receivers with manual and auto-drain. A manual bypass should be piped on site (kit available)
- A dryer frame with two dryer sub-assemblies, each including:
 - Manual isolating valves
 - Solenoid operating valves
 - Heatless desiccant dryer
 - Dew point alarm sensor
 - Coalescing filter
 - Activated carbon filter
 - Bacterial filter
 - Test point
 - Duplex pressure regulator/relief valve assembly
 - Dryer control units
 - Plant control unit
 - Plant to alarm interface

For more information about the specific components, please view the separate instruction manuals which are delivered with the respective machine.

1.2.1.1. Air Compressor

Air plant systems are available with oil-injected screw compressors or oil-free compressors. The later can be of the scroll, tooth or piston type. Each compressor is complete with auto-drain at the compressed air outlet. Each compressor also has temperature and pressure alarm sensors.

1.2.1.2. Air Receivers

One or more air receivers are supplied, and each receiver includes auto-drain with manual bypass, pressure relief valve, and fusible plug.

1.2.1.3. Dryer assembly with central controller

The dryer module consists of two duplex absorber towers containing activated alumina desiccant which reduces water vapour content to less than 1.0 gm/m³. When the plant is in operation one duplex tower is on stream removing water vapour from the air, the other tower is being dried and regenerated bypassing a small purge through it. No heating is required to achieve the specified standard of dryness.

The operation and regeneration cycle is fully automatic, controlled by the Purelogic® central controller, and requires no user input. Each tower is foreseen with a pressure switch. Also a dew point sensor is installed after the dryers so that should a fault occur, either high dew point or low pressure, an alarm signal is received by the control system and the standby dryer is activated. The plant control unit ensures that the dryer air purge does not continue under conditions of no load, ensuring efficient operation regardless of ambient air temperature and humidity.

In the event of a power failure the purge valves will close, and the operating valves will open, to allow the air to continue to reach the distribution system.

The system is intended to meet the specifications as shown in table 1-1.

Table 1-1; Specifications of Delivered Air

Specifications	
Oil content	≤ 0.1 mg/m
Dry Particulate	Not specified
CO	≤ 5 ppm v/v
CO ²	≤ 500 ppm v/v
O ²	≤ 1 ppm v/v
NO	≤ 2 ppm v/v
NO ²	≤ 2 ppm v/v
Atmospheric Dew point	-46°C

2 Technical Specification

Table 2-1; Technical Specification

Product name	
Physical Characteristics:	
Height	Varies with model
Width	Varies with model
Depth	Varies with model
Weight	Varies with model
Environmental Transport, Storage and Operating Conditions:	
Temperature transport/ storage	0 to 45°C
Operating Temperature	5 to 45°C
Humidity	0 to 95% R.H. Non-condensing
Air Pressure	70 to 130 kPa
Electrical Specification:	
Panel Electrical supply	Varies with model
Pump Electrical supply	Varies with model
Protection against electric shock	Class 1 (requires protective earth)
Mode of operation	Continuous (may be left on indefinitely)
Ingress Protection Class	IP4X (for indoor installation only)
Degree of mobility	Permanently installed
Performance:	
Volumetric flow rate	Varies with model
Regulatory Classification:	
GMDN Code (Term)	36271 (Medical gas and vacuum supply systems)
EC MDD Classification	Class IIb
GHTF Classification	Class C

3 User Responsibility

The Pneumatech Medical Gas Solutions Medical Air Plant has been built to conform to the specification and operating procedures stated in this manual and/ or accompanying labels and notices when checked, operated, maintained and serviced in accordance with these instructions.

To ensure the safety of this plant, it must be checked and serviced to at least the minimum standards laid out in this manual. A defective or suspected defective product must not be used under any circumstances.













The user must accept responsibility for any malfunction which results from non-compliance with the servicing requirements detailed in this manual. Additionally, the user must accept responsibility for any malfunction which may result from misuse of any kind, or non-compliance with other requirements detailed in this manual.

Worn, broken, distorted, contaminated or missing components must be replaced immediately. Should such a repair be necessary, it is recommended that a request for service advice be made to the nearest Pneumatech Medical Gas Solutions Service Centre.

This device and any of its constituent parts must be repaired only in accordance with written instructions issued by Pneumatech Medical Gas Solutions and must not be altered or modified in any way without the written approval of Pneumatech Medical Gas Solutions.

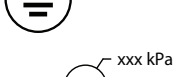
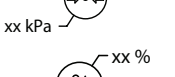
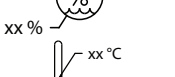
The user of this equipment shall have the sole responsibility for any malfunction which results from improper use, maintenance, repair, damage or alteration by anyone other than Pneumatech Medical Gas Solutions or their appointed agents.

4 Description of Symbols

WARNING!	Indicates a potentially hazardous situation which, if not avoided, could result in personal injury to the user or others.
CAUTION!	Indicates a potentially hazardous situation which, if not avoided, could result in damage to the device or property.
NOTE:	Emphasises points to achieve more convenient or efficient use of the device.
	Warning! Motor starts automatically
	Warning! Surfaces may be hot and should not be touched
	Warning! Dangerous voltage
	Warning! Beware of sudden loud noises
	Static sensitive components: take appropriate precautions
	Wear ear defenders
	Wear eye protection
	Wear hand protection
	Protective earth connection
	Ambient pressure range
	Ambient humidity range
	Ambient temperature range
	Consult accompanying documents
	Service due date
	The CE mark demonstrates that the product conforms to the requirements in the European Council Directive 93/42/EEC concerning medical devices. The number 0088 identifies the notifying body under which the Quality Systems operated within Pneumatech MGS.

- L Connection for the live conductor on permanently installed equipment
- N Connection for the neutral conductor on permanently installed equipment
- E Connection for the earth conductor on permanently installed equipment

5 Installation and Commissioning

Pneumatech Medical Air Plant should only be installed, commissioned and maintained by technicians who are suitably trained with piped medical gas systems, and who are fully conversant with the contract specifications and safety procedures.

5.1 Installation

5.1.1 Environmental Conditions

Warning! Keep all components dry and clean during installation.

Pneumatech Medical Gas Solutions Medical Gas plant, can be safely handled and stored under normal working and environmental conditions.

Adverse environmental conditions and harsh abrasives or chemicals may cause damage to the unit.

5.1.2 Electrical Supply

Electrical supply requirements vary with different compressor models. Incoming wiring must include neutral and earth.

5.1.3 Components

Inspect all components as they are unpacked.

Compressors are fitted with transportation bolts that must be removed before starting the compressor.

Identification - All Pneumatech MGS Medical Air plant is identified by a machine number, printed onto a label fixed to the frame of the PureMED dryer (see Figure i).

5.1.4 Plant Installation

5.1.4.1 Plant Room

Pneumatech MGS Medical Air Plant should be installed within a plant room that provides adequate ventilation, Be aware that 75% of all energy consumed is dissipated into the plant room. There should be at least 500mm space allowed between plant items and any walls or other obstructions.

Plant room ambient temperature: +5 to 35°C

Ventilation should be provided to ensure that the plant room temperature does not exceed ambient temperature by more than 10°C. If the temperature in the plant room is likely to exceed the maximum operating air intake temperature shown above, consideration should be given to duct the intake air from a cooler location.

5.1.4.2 Pipe work

Hard piped connections between the compressor outlet to vessel inlet, and from the vessel outlet to the medical dryer shall be conducted on site using degreased copper tube.

Please refer to technical data sheet 8102341120-4 for details on all inlet/outlet copper stub pipe sizes.

Note: Pipe sizing must be equal to or larger than and major component stub pipe. For installations where the components are positioned a long distances apart technical assistance should be requested to ensure there are no unacceptable pressure drops. Ideally piping should be taken from the compressor outlet to above head height, across and back down to the inlet of the vessels to ensure safety of the pipe system and to reduce obstructions getting to serviceable parts (same applies from the vessel outlet connection to the dryer inlet).

For layout details please refer to the general installation layout proposals available for each model. Drawing numbers are listed on technical data sheets 8102341120-4.

5.2 Commissioning

Commissioning is carried out in full after initial installation, after a major component change and as part of a planned preventative maintenance programme. The object of commissioning is to ensure that all components are serviceable, pressure switches operate at the correct settings and all alarm functions operate satisfactorily.

Personnel carrying out the following commissioning procedures must be qualified and fully conversant with the information contained in this manual.

5.2.1 Pre-test checks

Before starting the plant, ensure that the following have been completed:

1. Check that all pipes are connected, and that all unions made. Check that the plant is mechanically secure.
2. Ensure pressure relief valves are serviceable and unobstructed.
3. Check that all electrical connections are in place and that they have been correctly made.
4. Check that the compressors have been filled with the correct level of lubricant.
5. Check that the manual valves on the compressor outlets are open.
6. Check that the manual drains, the receiver by-pass valve, and the dryer inlet valves are closed.

6 Operating Instructions

Once installed and commissioned the plant control unit governs operation and no further input is required.

For the operating instruction of the separate components is referred to the instruction book that is delivered with that component.

The instructions for the compressors are delivered with each compressor.

The instructions for the dryers and the central controller are delivered with the PureMED dryer.

7 Maintenance

7.1 Introduction

Pneumatech MGS plant systems are designed to operate with the minimum of maintenance, however regular routine minor maintenance operations are recommended to prove the system integrity. Maintenance operations should be carried out in accordance with the planned preventative maintenance contract purchased by the customer. Maintenance engineers must fully understand the plant control system and must be conversant with the information contained in this manual. Service and Maintenance is limited to periodic checking and adjustment, or replacement if necessary, of components that develop a fault.

Warning! Use of sub-standard or inappropriate parts and materials may damage the plant system and invalidate the warranty.

Warning! Only use genuine Pneumatech Medical Gas Solutions spare parts.

Maintenance instructions for the dryer and compressor are handled in their respective instruction manuals.

7.2 Air receiver maintenance

The air receivers are designed / selected for specific applications and should not be used for other applications or otherwise modified except after detailed design verification by a competent authority.

The receiver should be regularly checked for condensate, using the manual drain valve, to confirm the correct operation of the auto drain.

The frequency of manual drainage should be determined on the basis of operating experience and dependent upon system air moisture content and the design of the overall system.

The receiver and associated pipe work should be inspected regularly for leaks, damage and signs of corrosion.

It is recommended that new seals and gaskets are used when refitting inspection plugs and door covers. Do not over tighten these closures.

7.3 Pressure relief valves

Pressure relief valves must only be inspected /replaced in accordance with the Pressure Equipment Regulations 1999 and the Pressure Systems Safety Regulations 2000. As a minimum safety relief valves should be replaced after 5 years.

7.4 Solenoid valve maintenance

Warning! Before working on solenoid valves isolate from the electrical supply and depressurize the valve.

It is not necessary to remove the solenoid valve from the line for repairs or service. Isolate the dryer first.

Periodic cleaning of the solenoid valves is desirable, the time between each cleaning operation being dependant on the media and service conditions.

In general, if the voltage to the coil is correct, sluggish valve operation, excessive noise or leakage will indicate that cleaning, service or renewal is required.

7.5 Regulator maintenance

Regulators must only be maintained /replaced in accordance with the Pressure Equipment Regulations 1999, and the Pressure Systems Safety Regulations 2000. To ensure trouble free service we recommended regulators are replaced or serviced biennially; this work must only be carried out by a competent person.

Note: This schedule only covers the basic service requirements. Items such as hoses, switch gear mountings etc. these must be inspected and replaced as required.

8 Recommended Spares

For all Service Spares enquiries, contact the Pneumatech Medical Gas Solutions Spares Department, giving as much of the following information as possible:

Plant certificate number and/or component serial numbers:

Product Part Number:

Lot / Batch Number:

Approximate date of purchase:

Part numbers of service kits and replacement parts can be found in the Spare Parts Lists of the PureMED and compressors.

Spares Department:

T: 44 (0) 1235 463053

F: 44 (0) 1235 463011

spares@p-mgs.com

Pneumatech Medical Gas Solutions

Unit 18 Nuffield Way

Abingdon

Oxfordshire

OX14 1RL UK

Sales

T: 44 (0) 1235 463010

F: 44 (0) 1235 463011

sales@p-mgs.com

Spares

T: 44 (0) 1235 463053

F: 44 (0) 1235 463011

spares@p-mgs.com

Service

T: 44 (0) 1235 463051

F: 44 (0) 1235 463011

service@p-mgs.com

Document Ref. 8102341049 Issue 00
Revision issue date: November 2015

© Atlas Copco 2015. All rights reserved.

Company Reg. Office: Swallowdale Lane, Hemel Hempstead, Hertfordshire HP2 7EA, UK

